

## Détails plage moteur Ausf a :

(Pose de barres dans les crevées d'admission d'air pour en réduire l'ouverture.)  
- Installation of bars in the air intake vents to reduce their opening. -

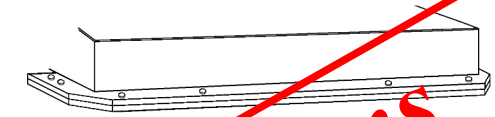

(Absence de renforts lors de la production.)  
- Lack of reinforcements during production. -

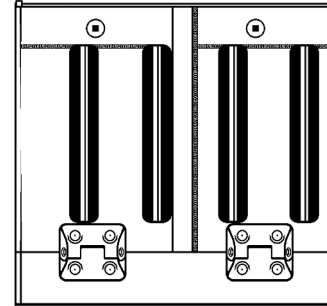

(Renforts par points de soudure sur les zones de faiblesse.)  
Welding reinforcements in weak areas. -

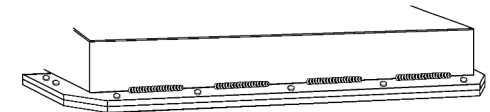

(Renforts préventifs par points de soudure réguliers.)  
- Preventive reinforcements with regular spot weldings. -

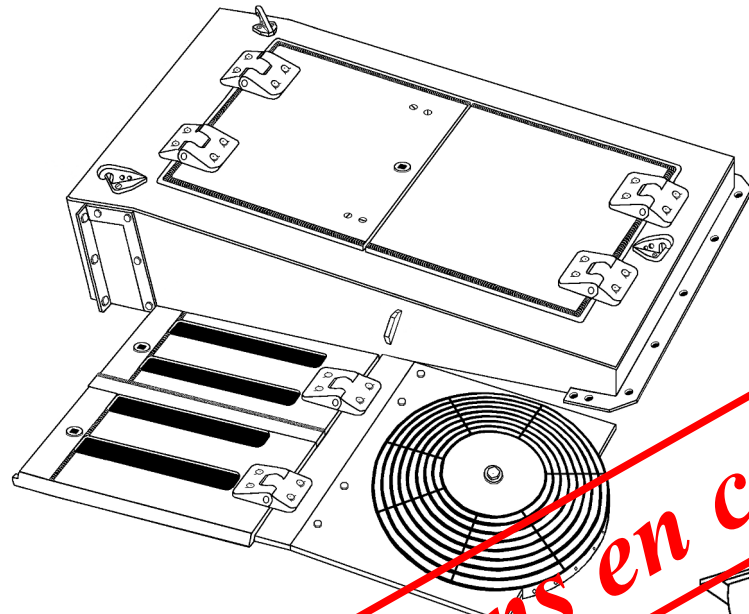

(Plage moteur Ausf a1, a2 & a3.)  
- Engine deck Ausf a1, a2 & a3. -

Nota :  
Les Panzerkampfwagen II Ausf a ne subiront pas de rénovations sur leur plage arrière. Les évolutions se feront à rebours avec les séries suivantes (Ausf b, c, d, e, f, g, h, i, j, k, l, m, n, o, p, q, r, s, t, u, v, w, x, y, z, aa, ab, ac, ad, ae, af, ag, ah, ai, aj, ak, al, am, an, ao, ap, aq, ar, as, at, au, av, aw, ax, ay, az, ba, bb, bc, bd, be, bf, bg, bh, bi, bj, bk, bl, bm, bn, bo, bp, bq, br, bs, bt, bu, bv, bw, bx, by, bz, ca, cb, cc, cd, ce, cf, cg, ch, ci, cj, ck, cl, cm, cn, co, cp, cq, cr, cs, ct, cu, cv, cw, cx, cy, cz, da, db, dc, dd, de, df, dg, dh, di, dj, dk, dl, dm, dn, do, dp, dq, dr, ds, dt, du, dv, dw, dx, dy, dz, ea, eb, ec, ed, ee, ef, eg, eh, ei, ej, ek, el, em, en, eo, ep, eq, er, es, et, eu, ev, ew, ex, ey, ez, fa, fb, fc, fd, fe, ff, fg, fh, fi, fj, fk, fl, fm, fn, fo, fp, fq, fr, fs, ft, fu, fv, fw, fx, fy, fz, ga, gb, gc, gd, ge, gf, gg, gh, gi, gj, gk, gl, gm, gn, go, gp, gq, gr, gs, gt, gu, gv, gw, gx, gy, gz, ha, hb, hc, hd, he, hf, hg, hh, hi, hj, hk, hl, hm, hn, ho, hp, hq, hr, hs, ht, hu, hv, hw, hx, hy, hz, ia, ib, ic, id, ie, if, ig, ih, ii, ij, ik, il, im, in, io, ip, iq, ir, is, it, iu, iv, iw, ix, iy, iz, ja, jb, jc, jd, je, jf, jg, jh, ji, jj, jk, jl, jm, jn, jo, jp, jq, jr, js, jt, ju, jv, jw, jx, jy, jz, ka, kb, kc, kd, ke, kf, kg, kh, ki, kj, kl, km, kn, ko, kp, kq, kr, ks, kt, ku, kv, kw, kx, ky, kz, la, lb, lc, ld, le, lf, lg, lh, li, lj, lk, ll, lm, ln, lo, lp, lq, lr, ls, lt, lu, lv, lw, lx, ly, lz, ma, mb, mc, md, me, mf, mg, mh, mi, mj, mk, ml, mm, mn, mo, mp, mq, mr, ms, mt, mu, mv, mw, mx, my, mz, na, nb, nc, nd, ne, nf, ng, nh, ni, nj, nk, nl, nm, nn, no, np, nq, nr, ns, nt, nu, nv, nw, nx, ny, nz, oa, ob, oc, od, oe, of, og, oh, oi, oj, ok, ol, om, on, oo, op, oq, or, os, ot, ou, ov, ow, ox, oy, oz, pa, pb, pc, pd, pe, pf, pg, ph, pi, pj, pk, pl, pm, pn, po, pp, pq, pr, ps, pt, pu, pv, pw, px, py, pz, qa, qb, qc, qd, qe, qf, qg, qh, qi, qj, qk, ql, qm, qn, qo, qp, qq, qr, qs, qt, qu, qv, qw, qx, qy, qz, ra, rb, rc, rd, re, rf, rg, rh, ri, rj, rk, rl, rm, rn, ro, rp, rq, rr, rs, rt, ru, rv, rw, rx, ry, rz, sa, sb, sc, sd, se, sf, sg, sh, si, sj, sk, sl, sm, sn, so, sp, sq, sr, ss, st, su, sv, sw, sx, sy, sz, ta, tb, tc, td, te, tf, tg, th, ti, tj, tk, tl, tm, tn, to, tp, tq, tr, ts, tt, tu, tv, tw, tx, ty, tz, ua, ub, uc, ud, ue, uf, ug, uh, ui, uj, uk, ul, um, un, uo, up, uq, ur, us, ut, uu, uv, uw, ux, uy, uz, va, vb, vc, vd, ve, vf, vg, vh, vi, vj, vk, vl, vm, vn, vo, vp, vq, vr, vs, vt, vu, vv, vw, vx, vy, vz, wa, wb, wc, wd, we, wf, wg, wh, wi, wj, wk, wl, wm, wn, wo, wp, wq, wr, ws, wt, wu, wv, ww, wx, wy, wz, xa, xb, xc, xd, xe, xf, xg, xh, xi, xj, xk, xl, xm, xn, xo, xp, xq, xr, xs, xt, xu, xv, xw, xx, xy, xz, ya, yb, yc, yd, ye, yf, yg, yh, yi, yj, yk, yl, ym, yn, yo, yp, yq, yr, ys, yt, yu, yv, yw, yx, yy, yz, za, zb, zc, zd, ze, zf, zg, zh, zi, zj, zk, zl, zm, zn, zo, zp, zq, zr, zs, zt, zu, zv, zw, zx, zy, zz).

- The Panzerkampfwagen II Ausf a will not undergo any renovations on the rear deck. The evolutions will be done in reverse with the following series (Ausf b & c). -

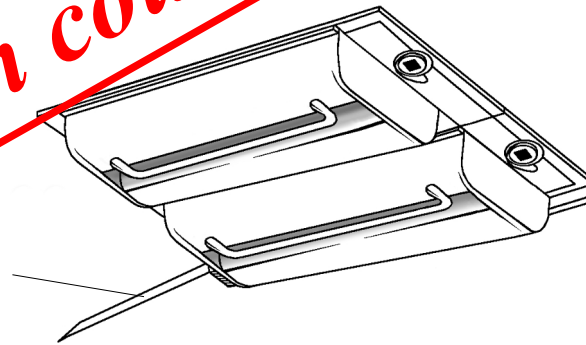

Verso et mécanisme de trappe Ausf a, b & c.)  
Reverse side and trap mechanism Ausf a, b & c. -

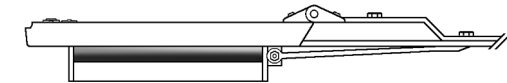

PAQUIS Jacky

**Corrections en cours**

**Ongoing corrections**